

Capacity 136 kg
(1 person 80 + tool box 56 kg)

Capacité 136 kg
(1 personne 80 + outils 56 kg)

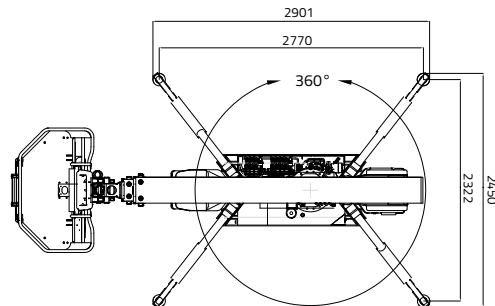

12,90 m

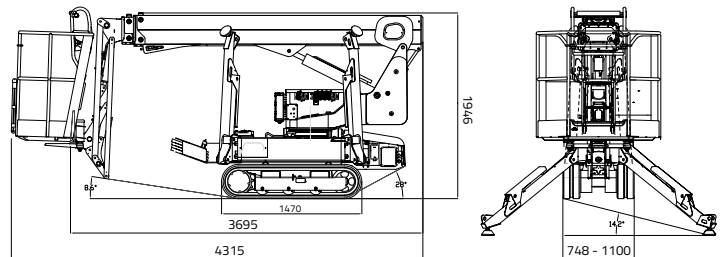

6,40 m



4,315 m



3,695 m



1,946 m



1305x600xh.1100 mm



1900 kg / 4189 lb



230V / 50 Hz - 2,2 kW
110V / 50 Hz - 2,2 kW
120V / 60 Hz - 1,2 kW



748 - 1100 mm



2770 x 2322 mm



Automatic set up system IIS std
IIS - Stabilisation et destabilisation
automatique IIS de série



Remote control
Télécommande



GPRS-GPS



R.A.H.M.



Battery Paquet de batteries 80Ah
Electric motor Moteur électrique :
- rated voltage tension nominale 48 V
- rated power puissance nominale 2 kW
Onboard battery charger
Chargeur de batterie à bord
110V-220V+-30V 50-60 Hz

Confidential, not to share
before April 24

PREVIEW